

Avion			
Fig	Aresti	K	
1 C	1.3.14.1	22	48
	9.1.1.2	8	
	9.2.4.4	9	
	9.4.1.2	9	
2	1.1.7.4	9	16
	9.12.1.4	7	
3	8.4.1.1	13	30
	9.4.1.4	15	
	9.1.5.1	2	
4 D	8.8.6.1	21	32
	9.8.1.1	7	
	9.1.5.2	4	
5	7.5.5.3	15	50
	9.9.3.6	14	
	9.1.2.1	4	
	9.1.2.3	8	
	9.2.3.4	9	
6 A	5.3.2.1	24	35
	9.1.2.2	6	
	9.4.5.2	5	
7 B	7.2.2.1	6	29
	9.2.3.6	12	
	9.9.3.4	11	
8	8.4.3.1	15	27
	9.1.1.1	6	
	9.1.5.3	6	
9 E	7.3.2.1	14	31
	9.4.2.2	7	
	9.1.2.4	10	
10	2.2.5.1	22	22
<b>Total K = 320</b> (max K = 320)			

		Form B
Pilote ID	France Advanced connu-libre	Vol N° 2

← VENT

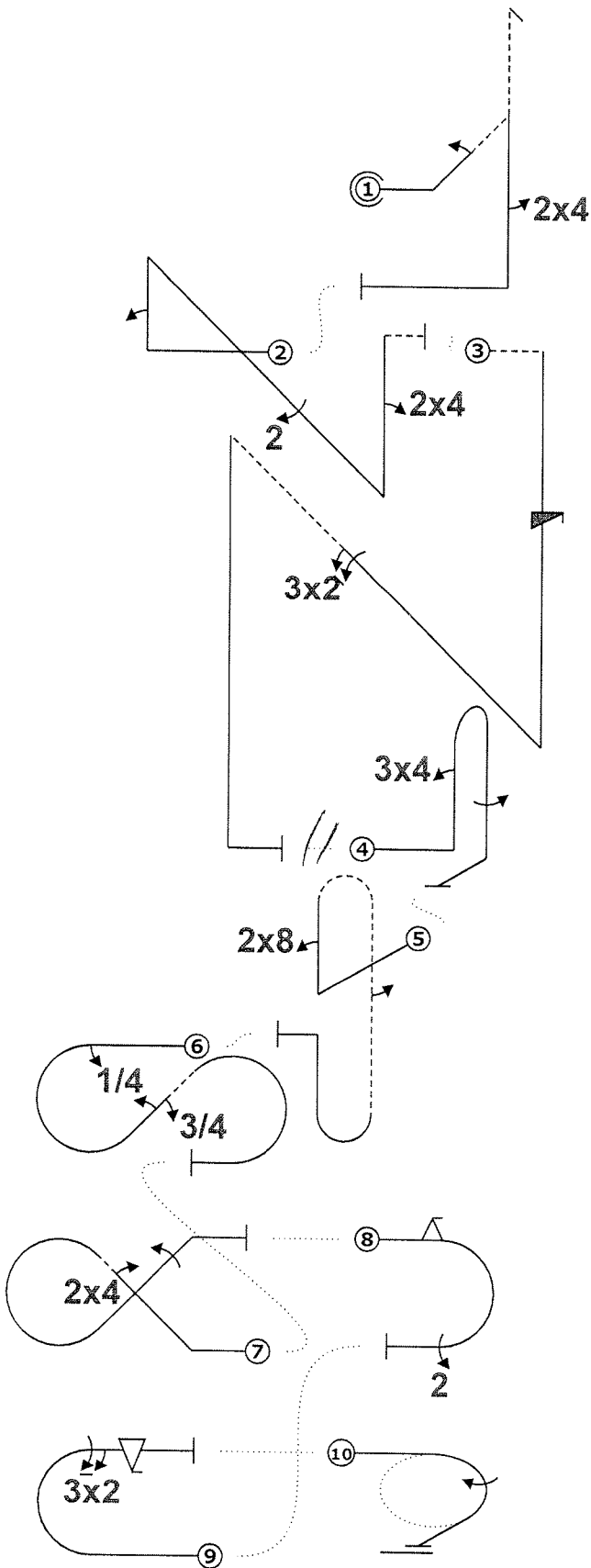

Avion			
Fig	Aresti	K	
1 A	5.3.2.1	24	35
	9.1.2.2	6	
	9.4.5.2	5	
2 C	1.3.14.1	22	48
	9.1.1.2	8	
	9.2.4.4	9	
	9.4.1.2	9	
3	1.3.11.4	20	41
	9.12.1.4	7	
	9.2.2.6	14	
4	8.4.1.1	13	33
	9.4.1.3	12	
	9.1.5.4	8	
5 D	8.8.6.1	21	32
	9.8.1.1	7	
	9.1.5.2	4	
6	7.5.5.3	15	31
	9.1.3.2	4	
	9.1.2.1	4	
	9.1.2.3	8	
7 E	7.3.2.1	14	31
	9.4.2.2	7	
	9.1.2.4	10	
8	7.2.3.3	6	26
	9.9.3.2	11	
	9.2.3.4	9	
9 B	7.2.2.1	6	29
	9.2.3.6	12	
	9.9.3.4	11	
10	2.1.3.1	14	14
<b>Total K = 320</b>		<b>(max K = 320)</b>	

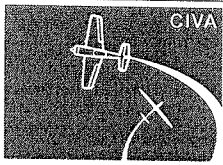

FAI

AEROBATICS  
COMMISSION

Pilote ID

CIVA Advanced Programme1

Form B

Vol N°

3

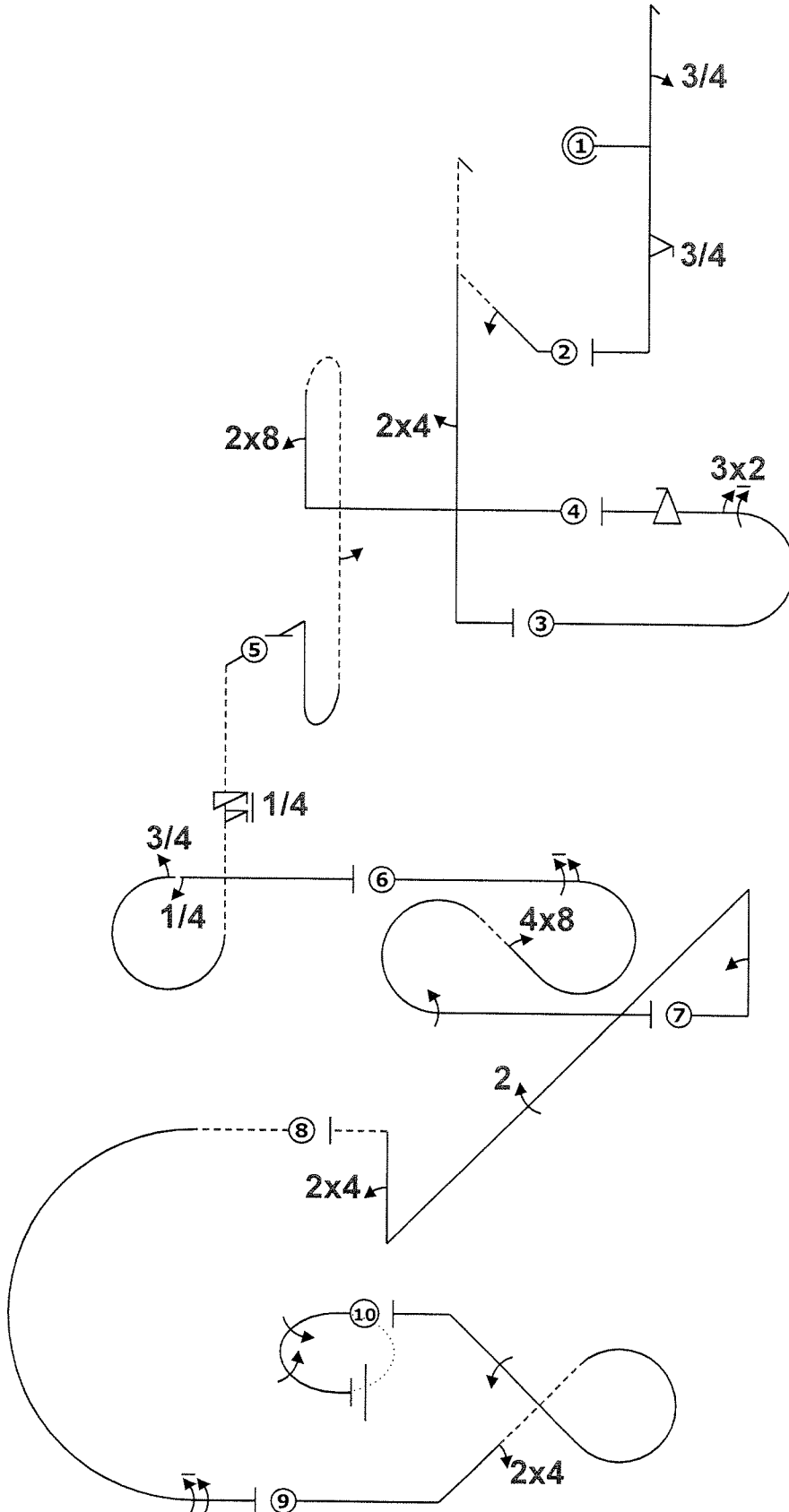

Avion			
Fig	Aresti	K	
1	5.2.1.1	17	38
	9.1.1.3	10	
	9.9.5.3	11	
2 A	5.3.2.1	24	35
	9.1.2.2	6	
	9.4.5.2	5	
3 B	7.2.2.1	6	29
	9.2.3.6	12	
	9.9.3.4	11	
4 D	8.8.6.1	21	32
	9.8.1.1	7	
	9.1.5.2	4	
5	8.6.4.3	13	25
	9.11.1.5	4	
	9.1.3.3	6	
	9.1.3.1	2	
6	7.5.5.3	15	42
	9.1.3.6	10	
	9.8.2.2	9	
	9.1.3.4	8	
7 C	1.3.14.1	22	48
	9.1.1.2	8	
	9.2.4.4	9	
	9.4.1.2	9	
8	7.2.1.4	6	18
	9.1.3.8	12	
9 E	7.3.2.1	14	31
	9.4.2.2	7	
	9.1.2.4	10	
10	2.2.5.1	22	22
<b>Total K = 320</b> (max K = 320)			

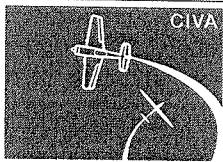

**FAI** AEROBATICS COMMISSION

		Form B
Pilote ID	CIVA Advanced Programme1	Vol N° <b>4</b>

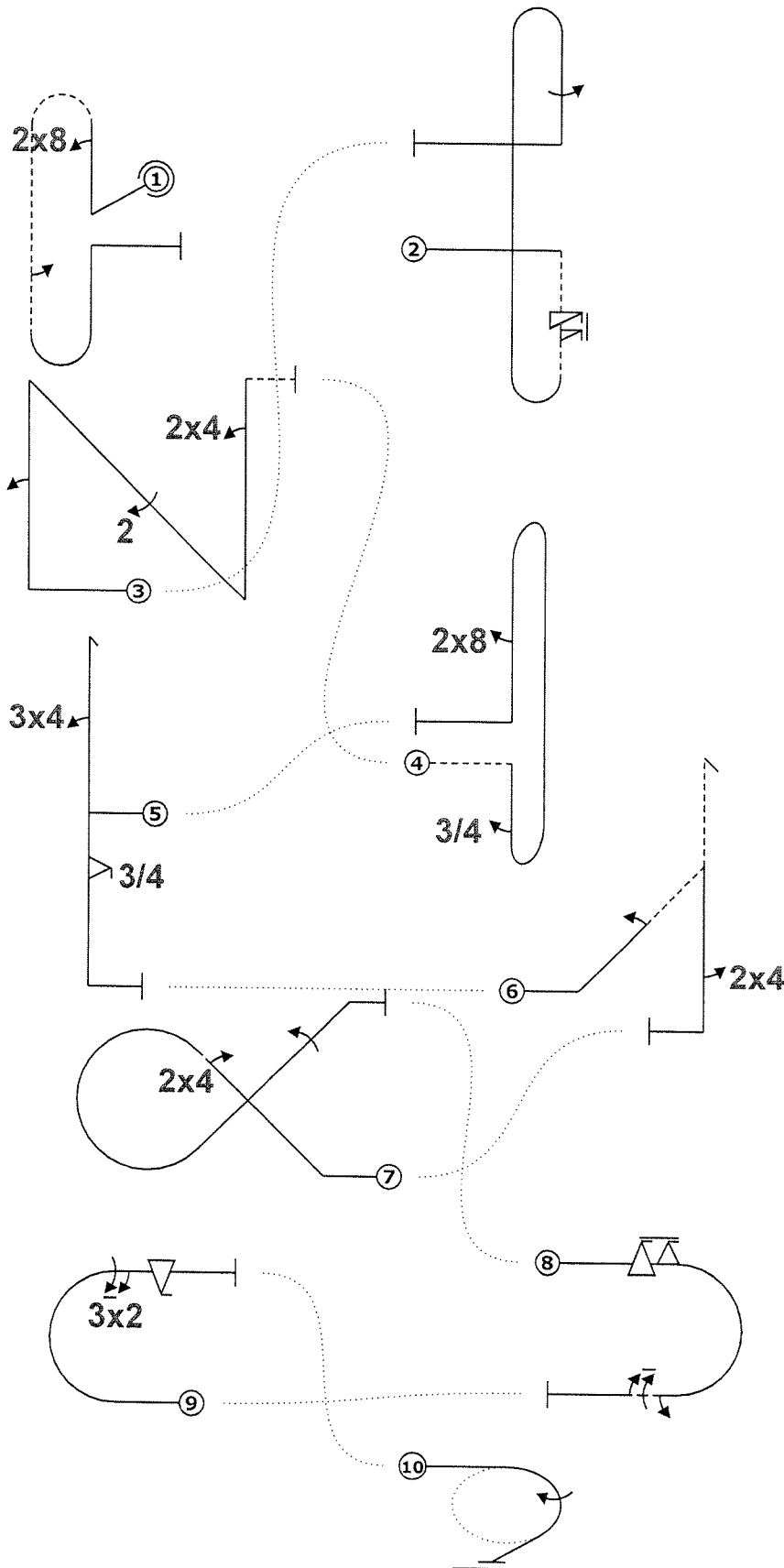
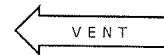

Avion			
Fig	Aresti	K	
1 D	8.8.6.1	21	32
	9.8.1.1	7	
	9.1.5.2	4	
2	8.8.8.3	19	30
	9.11.1.6	3	
	9.1.5.4	8	
3 C	1.3.14.1	22	48
	9.1.1.2	8	
	9.2.4.4	9	
	9.4.1.2	9	
4	8.8.1.4	18	27
	9.1.5.3	6	
	9.8.5.1	3	
5	5.2.1.1	17	40
	9.4.1.3	12	
	9.9.5.3	11	
6 A	5.3.2.1	24	35
	9.1.2.2	6	
	9.4.5.2	5	
7 E	7.3.2.1	14	31
	9.4.2.2	7	
	9.1.2.4	10	
8	7.2.3.3	6	34
	9.9.3.6	14	
	9.1.3.2	4	
	9.1.3.6	10	
9 B	7.2.2.1	6	29
	9.2.3.6	12	
	9.9.3.4	11	
10	2.1.3.1	14	14
<b>Total K = 320</b> (max K = 320)			

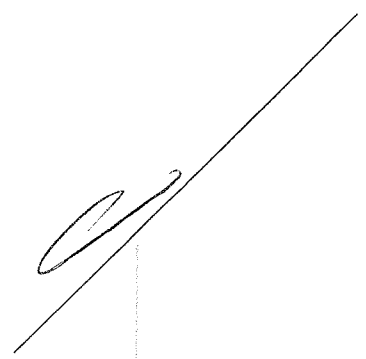

Pilote ID

CIVA Advanced Programme1

Vol N°  
5

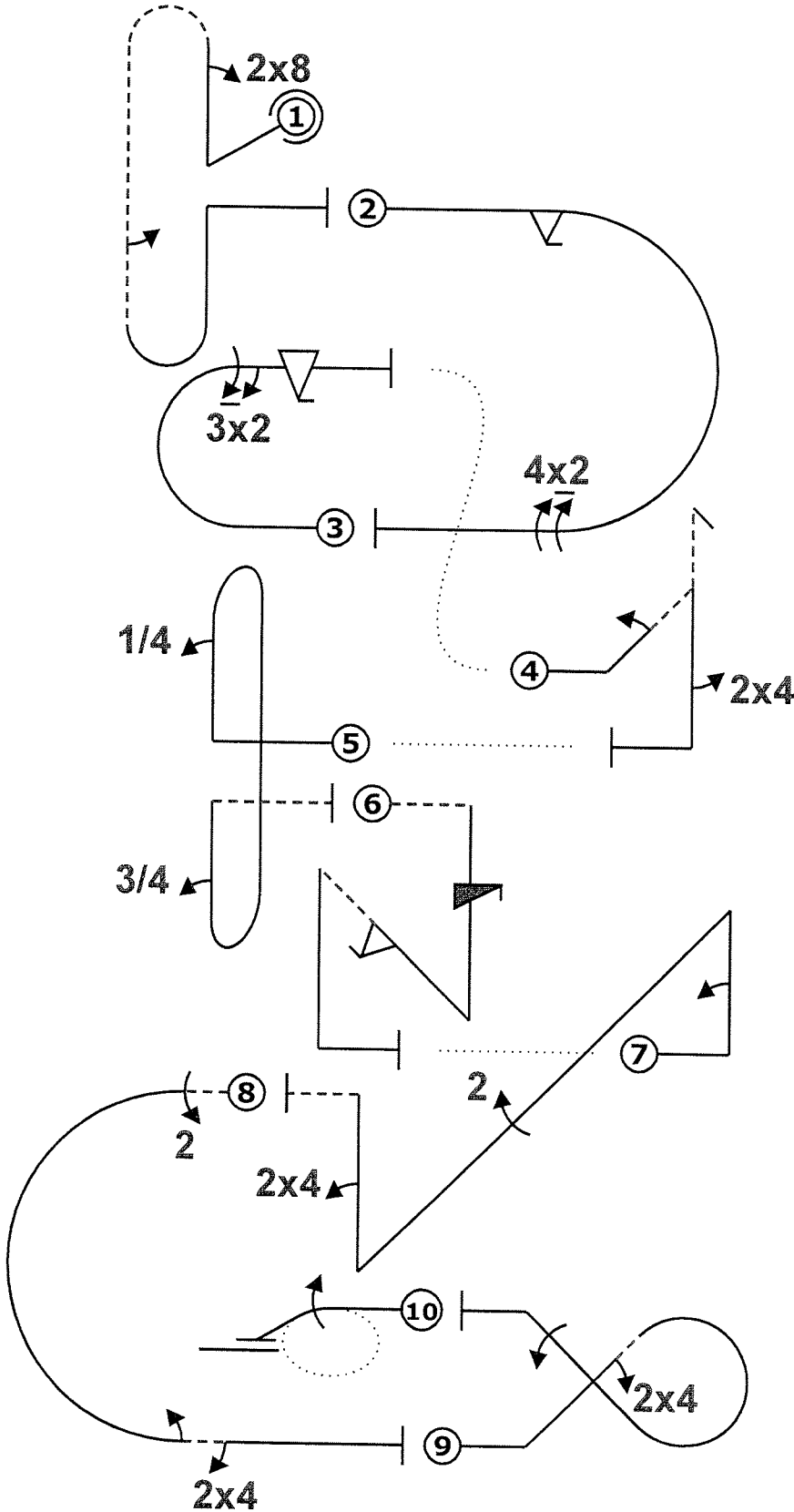

Avion			
Fig	Aresti	K	
1 D	8.8.6.1	21	32
	9.8.1.1	7	
	9.1.5.2	4	
2	7.2.3.3	6	32
	9.9.3.2	11	
	9.2.3.8	15	
3 B	7.2.2.1	6	29
	9.2.3.6	12	
	9.9.3.4	11	
4 A	5.3.2.1	24	35
	9.1.2.2	6	
	9.4.5.2	5	
5	8.8.1.1	18	34
	9.1.1.1	6	
	9.1.1.3	10	
6	1.3.11.4	20	40
	9.12.1.4	7	
	9.9.2.2	13	
7 C	1.3.14.1	22	48
	9.1.1.2	8	
	9.2.4.4	9	
	9.4.1.2	9	
8	7.2.1.4	6	24
	9.2.3.4	9	
	9.1.3.2	4	
	9.4.3.2	5	
9 E	7.3.2.1	14	31
	9.4.2.2	7	
	9.1.2.4	10	
10	2.1.3.3	15	15
<b>Total K = 320</b> (max K = 320)			

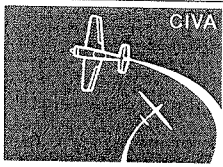

FAI

AEROBATICS  
COMMISSION

Form B

Pilote ID

CIVA Advanced Programme1

Vol N°

6

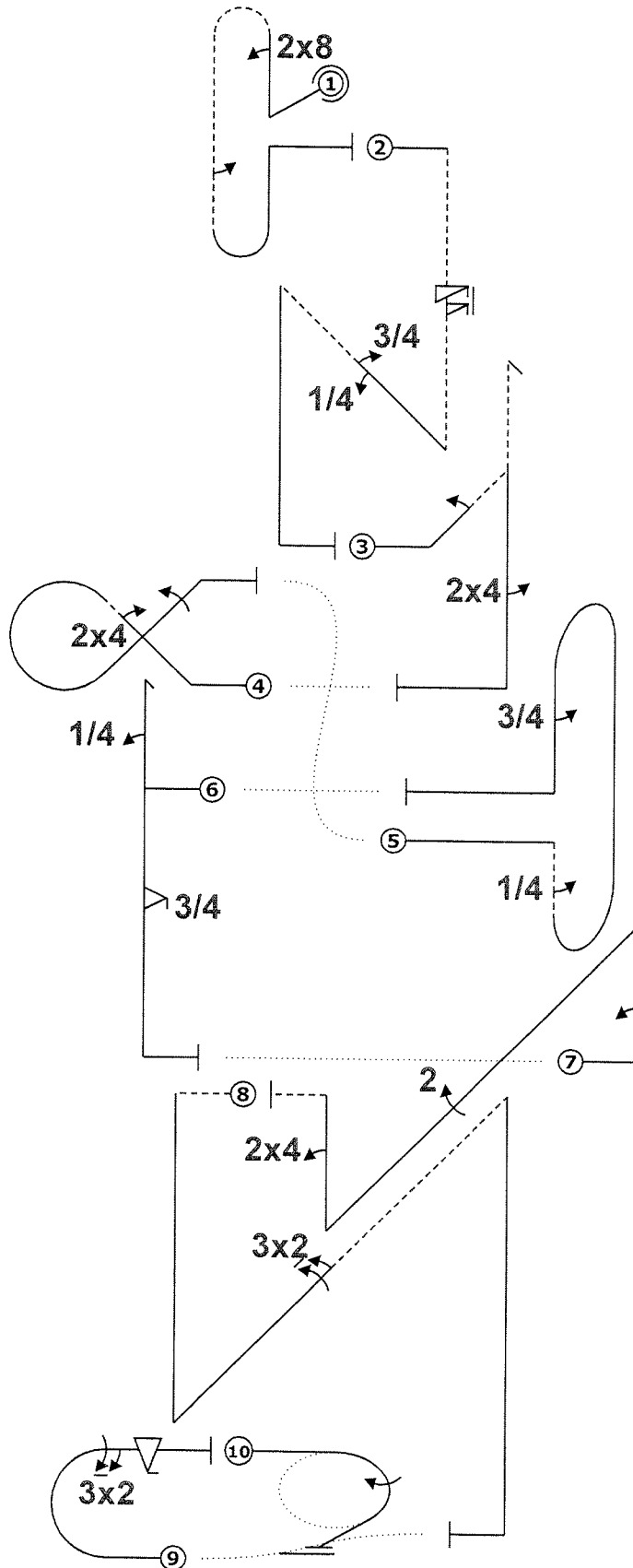

Avion			
Fig	Aresti	K	
1 D	8.8.6.1	21	32
	9.8.1.1	7	
	9.1.5.2	4	
2	1.3.16.3	21	36
	9.11.1.6	3	
	9.1.2.1	4	
	9.1.2.3	8	
3 A	5.3.2.1	24	35
	9.1.2.2	6	
	9.4.5.2	5	
4 E	7.3.2.1	14	31
	9.4.2.2	7	
	9.1.2.4	10	
5	8.8.8.3	19	27
	9.1.5.1	2	
	9.1.5.3	6	
6	5.2.1.1	17	34
	9.1.1.1	6	
	9.9.5.3	11	
7 C	1.3.14.1	22	48
	9.1.1.2	8	
	9.2.4.4	9	
	9.4.1.2	9	
8	1.3.11.4	20	34
	9.2.2.6	14	
9 B	7.2.2.1	6	29
	9.2.3.6	12	
	9.9.3.4	11	
10	2.1.3.1	14	14
<b>Total K = 320</b> (max K = 320)			

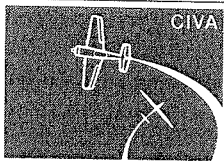

FAI

AEROBATICS  
COMMISSION

Pilote ID

CIVA Advanced Programme1

Form B

Vol N°

7

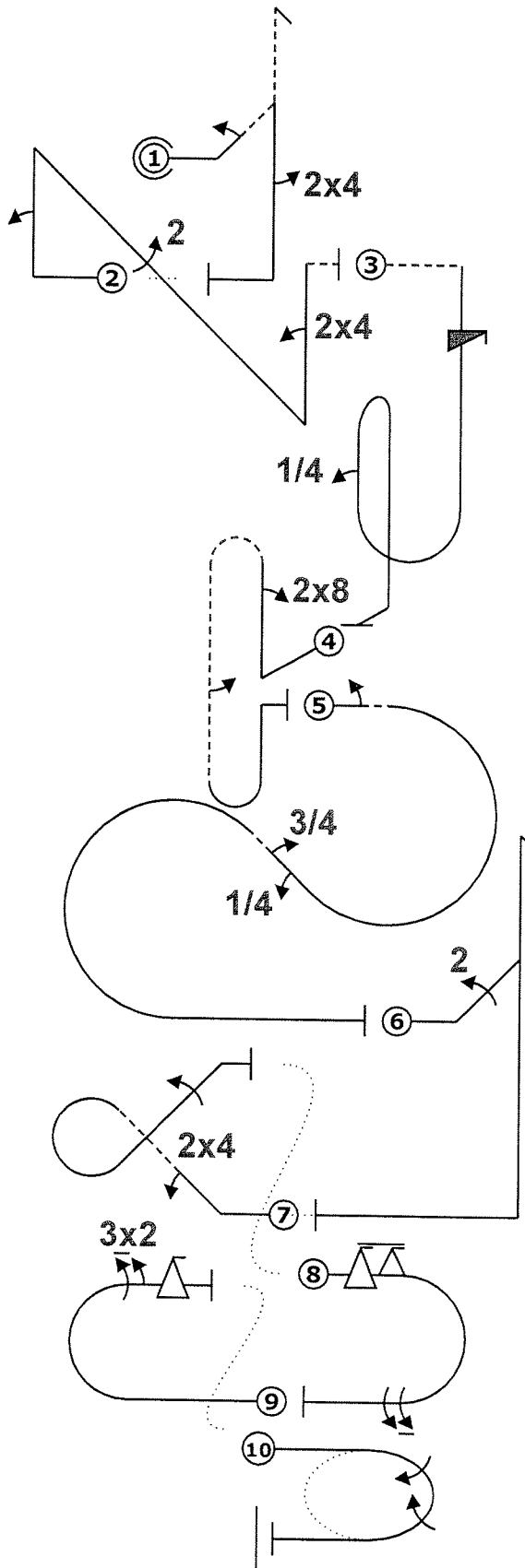

Avion			
Fig	Aresti	K	
1 A	5.3.2.1	24	35
	9.1.2.2	6	
	9.4.5.2	5	
2 C	1.3.14.1	22	48
	9.1.1.2	8	
	9.2.4.4	9	
	9.4.1.2	9	
3	8.8.1.4	18	31
	9.12.1.4	7	
	9.1.1.1	6	
4 D	8.8.6.1	21	32
	9.8.1.1	7	
	9.1.5.2	4	
5	7.5.5.3	15	31
	9.1.3.2	4	
	9.1.2.1	4	
	9.1.2.3	8	
6	5.3.1.1	18	29
	9.2.2.4	11	
7 E	7.3.2.1	14	31
	9.4.2.2	7	
	9.1.2.4	10	
8	7.2.3.3	6	32
	9.9.3.6	14	
	9.1.3.8	12	
9 B	7.2.2.1	6	29
	9.2.3.6	12	
	9.9.3.4	11	
10	2.2.5.1	22	22
<b>Total K = 320</b> (max K = 320)			

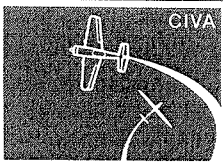

**FAI**  
AEROBATICS  
COMMISSION

Chambley 14/06/2021

Form B

Pilote ID

CIVA Advanced Free Known

Vol N°

8

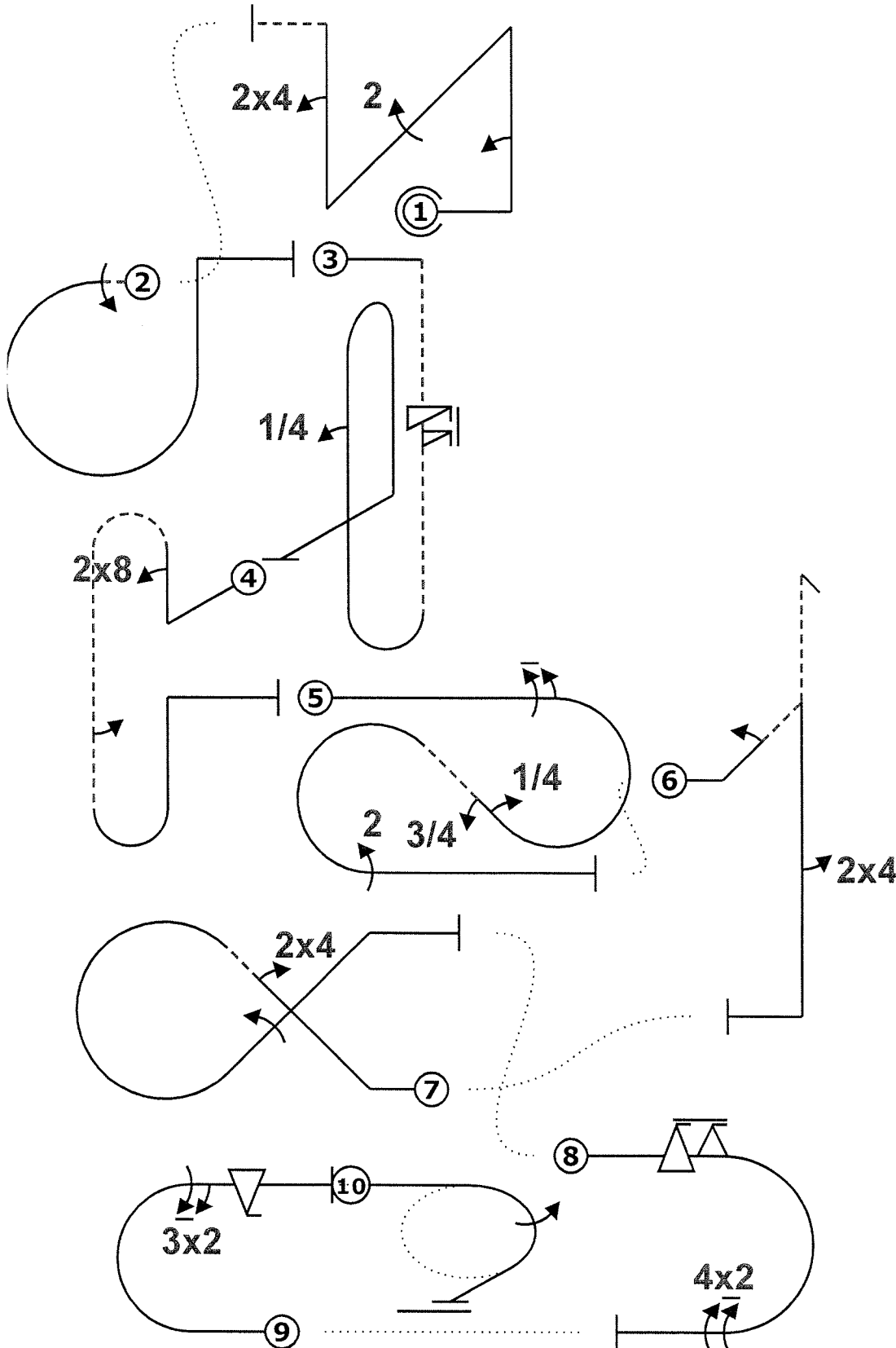

Avion			
Fig	Aresti	K	
1 C	1.3.14.1	22	48
	9.1.1.2	8	
	9.2.4.4	9	
	9.4.1.2	9	
2	8.6.6.4	13	21
	9.1.3.4	8	
3	8.8.8.3	19	28
	9.11.1.6	3	
	9.1.1.1	6	
4 D	8.8.6.1	21	32
	9.8.1.1	7	
	9.1.5.2	4	
5	7.5.5.3	15	46
	9.1.3.6	10	
	9.1.2.1	4	
	9.1.2.3	8	
6 A	5.3.2.1	24	35
	9.1.2.2	6	
	9.4.5.2	5	
7 E	7.3.2.1	14	31
	9.4.2.2	7	
	9.1.2.4	10	
8	7.2.3.3	6	35
	9.9.3.6	14	
	9.2.3.8	15	
9 B	7.2.2.1	6	29
	9.2.3.6	12	
	9.9.3.4	11	
10	2.1.3.3	15	15
<b>Total K = 320</b> (max K = 320)			



		Form B
Pilote ID	France Advanced connu-libre	Vol N° <span style="font-size: 2em;">9</span>

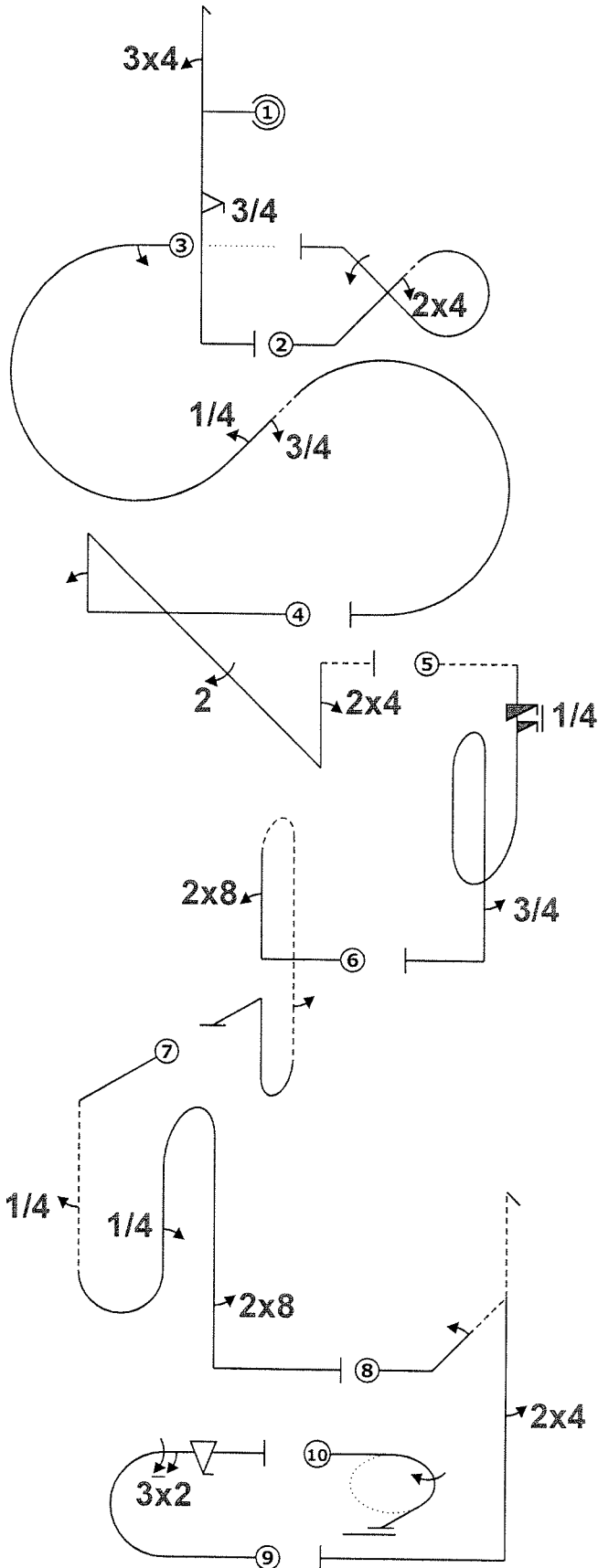

Avion			
Fig	Aresti	K	
1	5.2.1.1	17	40
	9.4.1.3	12	
	9.9.5.3	11	
2 E	7.3.2.1	14	31
	9.4.2.2	7	
	9.1.2.4	10	
3	7.5.5.3	15	31
	9.1.3.2	4	
	9.1.2.1	4	
	9.1.2.3	8	
4 C	1.3.14.1	22	48
	9.1.1.2	8	
	9.2.4.4	9	
	9.4.1.2	9	
5	8.8.1.4	18	30
	9.12.1.5	6	
	9.1.5.3	6	
6 D	8.8.6.1	21	32
	9.8.1.1	7	
	9.1.5.2	4	
7	8.8.8.3	19	30
	9.1.5.1	2	
	9.1.1.1	6	
	9.8.5.1	3	
8 A	5.3.2.1	24	35
	9.1.2.2	6	
	9.4.5.2	5	
9 B	7.2.2.1	6	29
	9.2.3.6	12	
	9.9.3.4	11	
10	2.1.3.1	14	14
<b>Total K = 320</b> (max K = 320)			

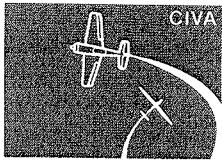

FAI

AEROBATICS  
COMMISSION

Pilote ID

CIVA Advanced Programme1

Form B

Vol N°

10

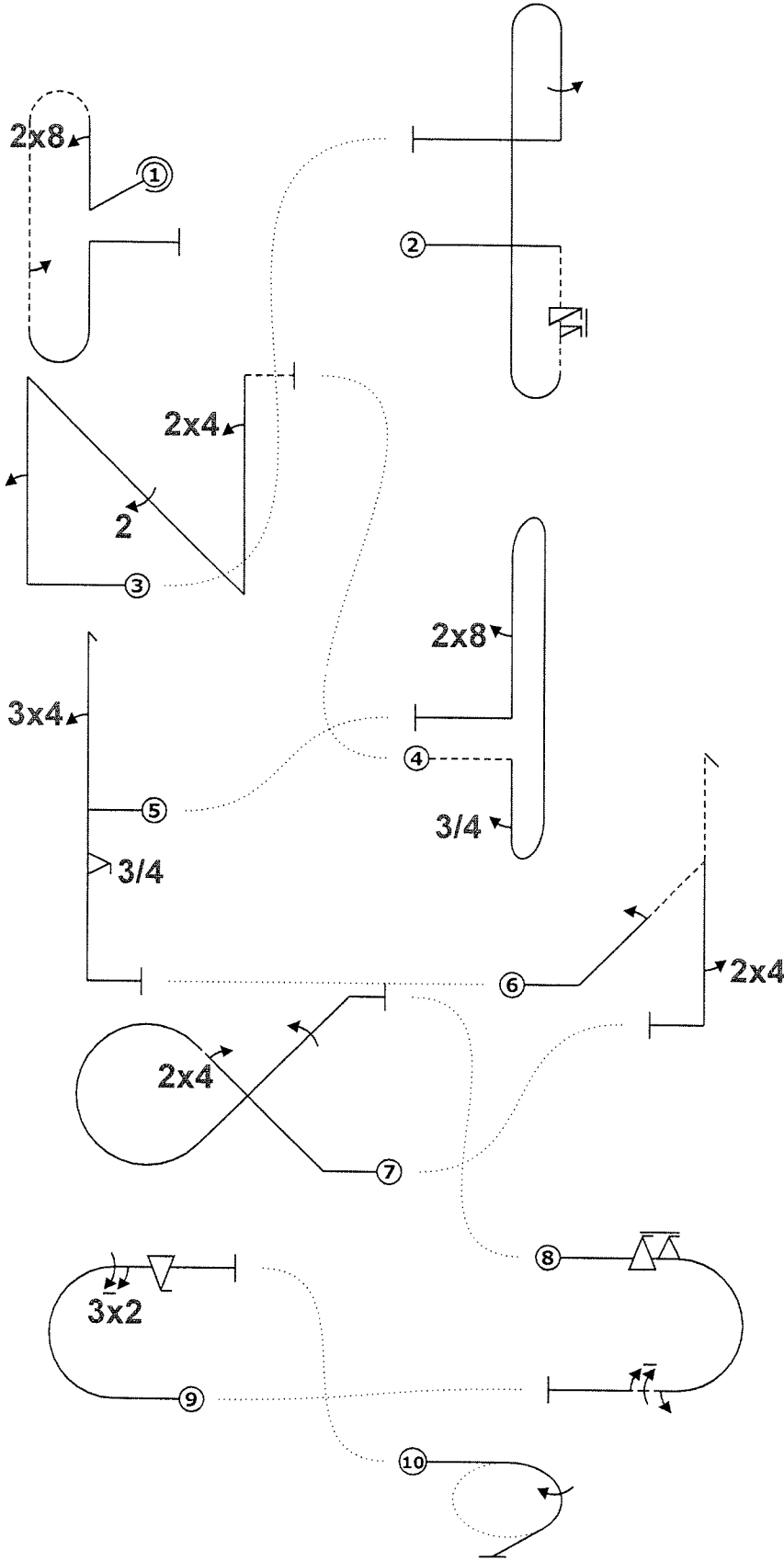

Avion			
Fig	Aresti	K	
1 D	8.8.6.1	21	32
	9.8.1.1	7	
	9.1.5.2	4	
2	8.8.8.3	19	30
	9.11.1.6	3	
	9.1.5.4	8	
3 C	1.3.14.1	22	48
	9.1.1.2	8	
	9.2.4.4	9	
	9.4.1.2	9	
4	8.8.1.4	18	27
	9.1.5.3	6	
	9.8.5.1	3	
5	5.2.1.1	17	40
	9.4.1.3	12	
	9.9.5.3	11	
6 A	5.3.2.1	24	35
	9.1.2.2	6	
	9.4.5.2	5	
7 E	7.3.2.1	14	31
	9.4.2.2	7	
	9.1.2.4	10	
8	7.2.3.3	6	34
	9.9.3.6	14	
	9.1.3.2	4	
	9.1.3.6	10	
9 B	7.2.2.1	6	29
	9.2.3.6	12	
	9.9.3.4	11	
10	2.1.3.1	14	14
<b>Total K = 320</b> (max K = 320)			

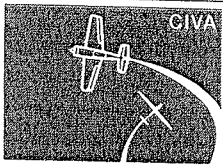

Form B

Pilote ID

CIVA Advanced Programme1

Vol N°

*AA*

**FAI**  
AEROBATICS  
COMMISSION

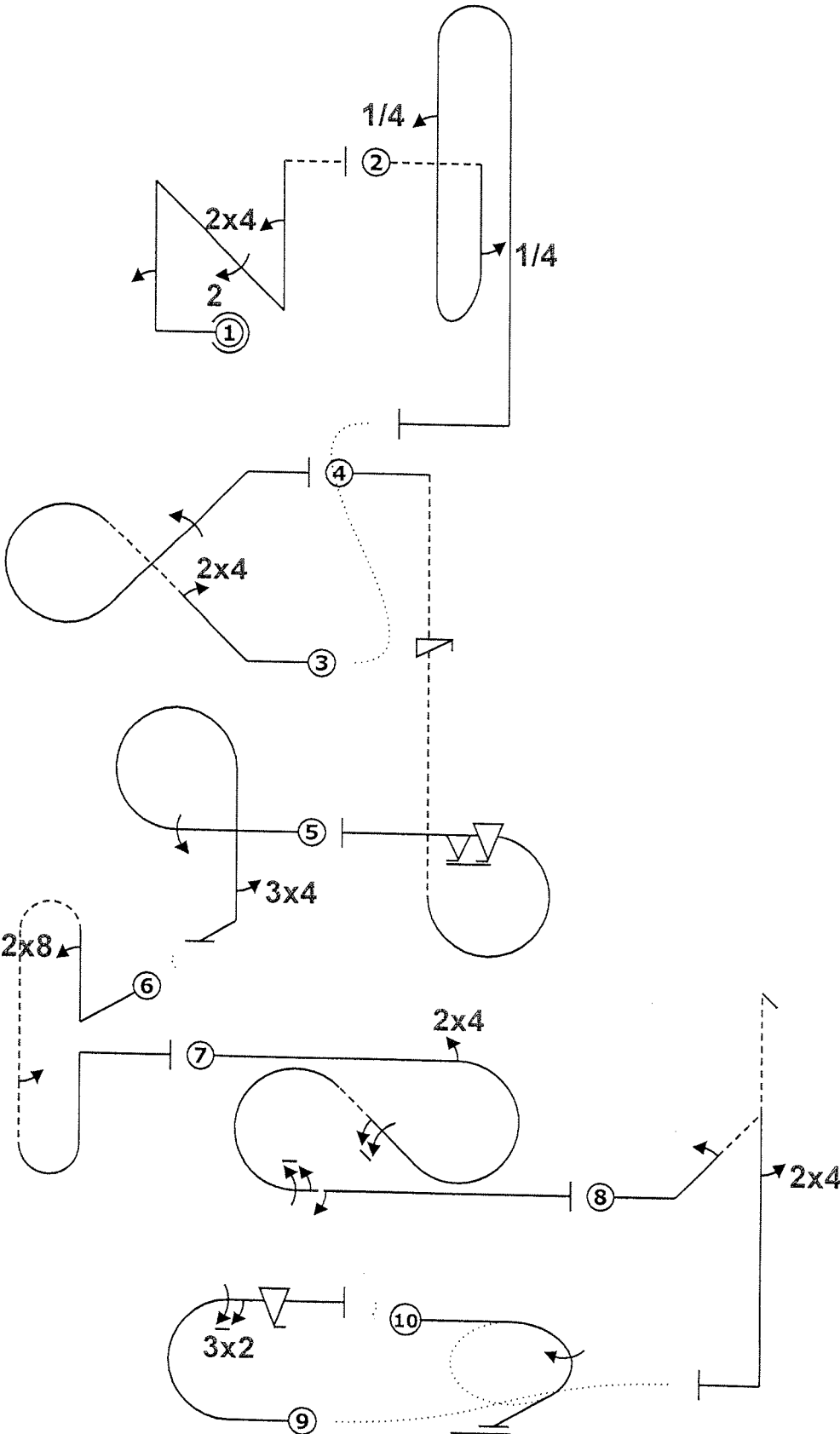

Avion			
Fig	Aresti	K	
1 C	1.3.14.1	22	48
	9.1.1.2	8	
	9.2.4.4	9	
	9.4.1.2	9	
2	8.8.1.4	18	26
	9.1.5.1	2	
	9.1.1.1	6	
3 E	7.3.2.1	14	31
	9.4.2.2	7	
	9.1.2.4	10	
4	8.6.4.3	13	32
	9.11.1.4	5	
	9.9.3.6	14	
5	8.6.5.1	11	27
	9.1.3.4	8	
	9.4.5.3	8	
6 D	8.8.6.1	21	32
	9.8.1.1	7	
	9.1.5.2	4	
7	7.5.5.3	15	46
	9.4.3.2	5	
	9.1.2.6	12	
	9.1.3.6	10	
	9.1.3.2	4	
8 A	5.3.2.1	24	35
	9.1.2.2	6	
	9.4.5.2	5	
9 B	7.2.2.1	6	29
	9.2.3.6	12	
	9.9.3.4	11	
10	2.1.3.1	14	14
<b>Total K = 320</b> (max K = 320)			

Pilote ID		Form B
France Advanced connu-libre		Vol N° 12

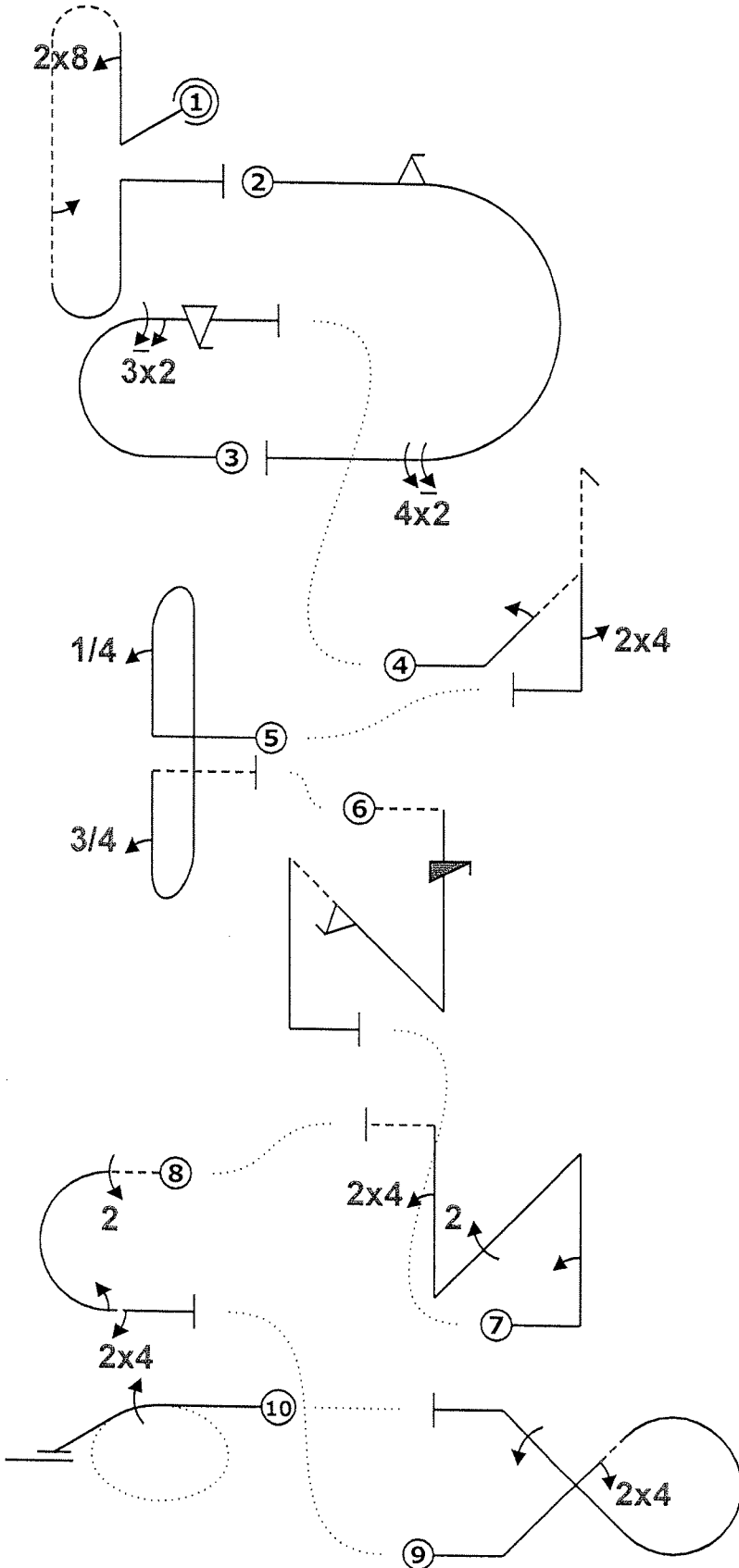

Avion			
Fig	Aresti	K	
1 D	8.8.6.1	21	32
	9.8.1.1	7	
	9.1.5.2	4	
2	7.2.3.3	6	32
	9.9.3.2	11	
	9.2.3.8	15	
3 B	7.2.2.1	6	29
	9.2.3.6	12	
	9.9.3.4	11	
4 A	5.3.2.1	24	35
	9.1.2.2	6	
	9.4.5.2	5	
5	8.8.1.1	18	34
	9.1.1.1	6	
	9.1.1.3	10	
6	1.3.11.4	20	40
	9.12.1.4	7	
	9.9.2.2	13	
7 C	1.3.14.1	22	48
	9.1.1.2	8	
	9.2.4.4	9	
	9.4.1.2	9	
8	7.2.1.4	6	24
	9.2.3.4	9	
	9.1.3.2	4	
	9.4.3.2	5	
9 E	7.3.2.1	14	31
	9.4.2.2	7	
	9.1.2.4	10	
10	2.1.3.3	15	15
<b>Total K = 320</b> (max K = 320)			

Pilote ID		Form B
France Advanced connu-libre		Vol N° 13

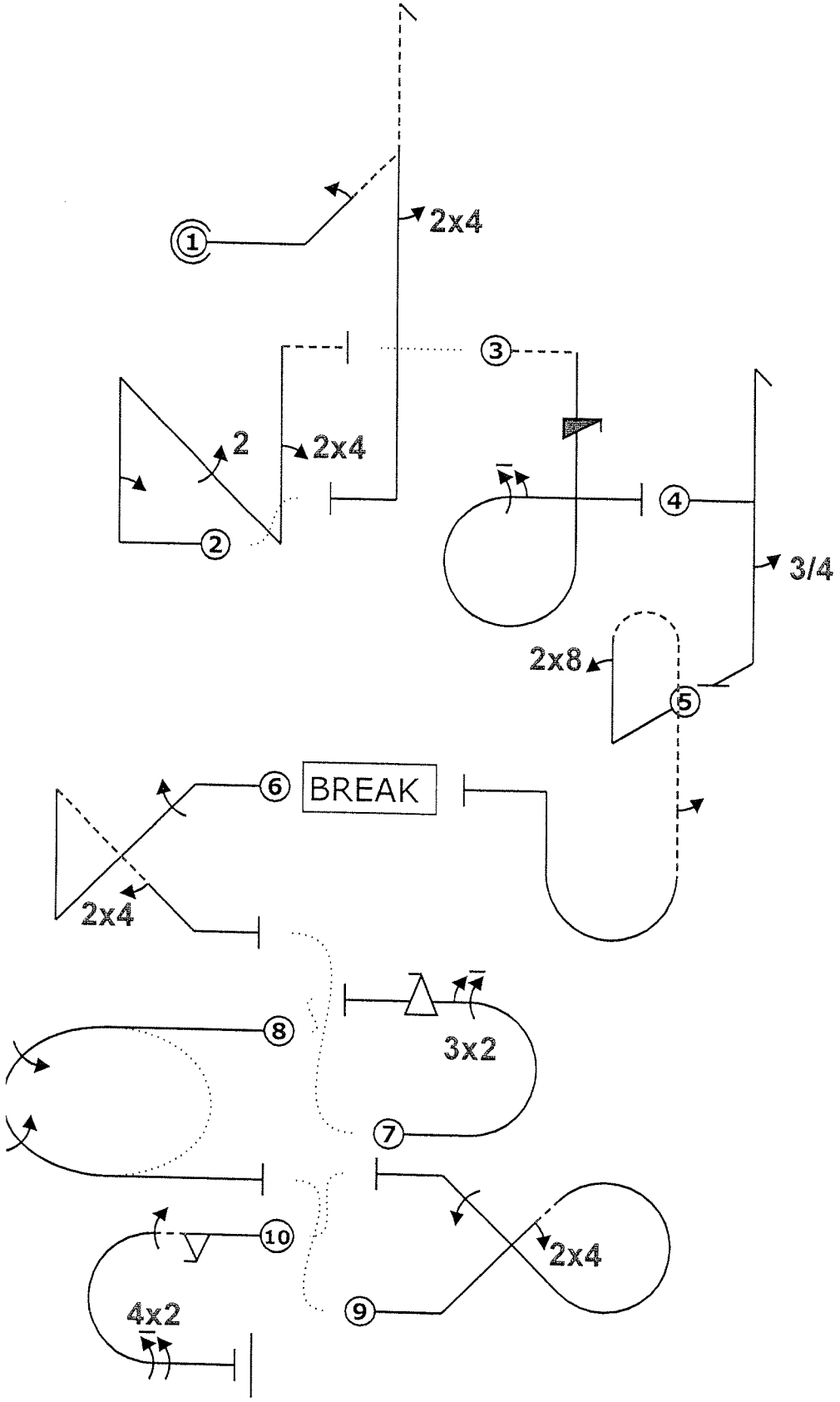

Avion			
Fig	Aresti	K	
1 A	5.3.2.1	24	35
	9.1.2.2	6	
	9.4.5.2	5	
2 C	1.3.14.1	22	48
	9.1.1.2	8	
	9.2.4.4	9	
	9.4.1.2	9	
3	8.6.2.4	12	29
	9.12.1.4	7	
	9.1.3.6	10	
4	5.2.1.1	17	23
	9.1.5.3	6	
5 D	8.8.6.1	21	32
	9.8.1.1	7	
	9.1.5.2	4	
6	1.3.3.3	18	31
	9.1.4.4	8	
	9.4.4.2	5	
7 B	7.2.2.1	6	29
	9.2.3.6	12	
	9.9.3.4	11	
8	2.2.5.1	22	22
9 E	7.3.2.1	14	31
	9.4.2.2	7	
	9.1.2.4	10	
10	7.2.3.3	6	40
	9.9.3.2	11	
	9.1.3.4	8	
	9.2.3.8	15	
<b>Total K = 320</b> (max K = 320)			

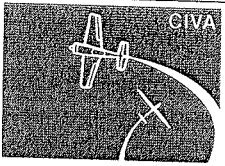

FAI

AEROBATICS  
COMMISSION

Pilote ID

CIVA Advanced Free Known

Form B

Vol N°

14

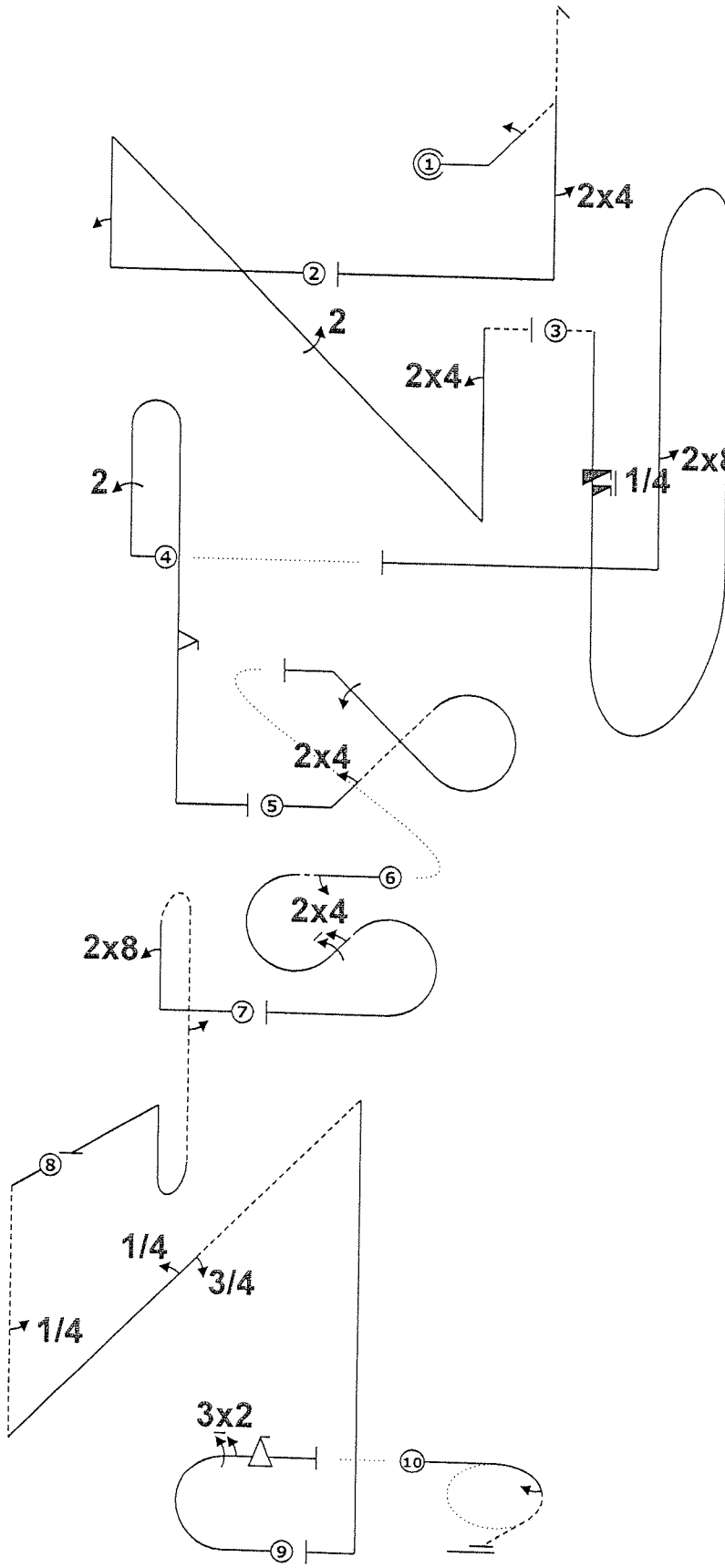

Avion			
Fig	Aresti	K	
1 A	5.3.2.1	24	35
	9.1.2.2	6	
	9.4.5.2	5	
2 C	1.3.14.1	22	48
	9.1.1.2	8	
	9.2.4.4	9	
	9.4.1.2	9	
3	8.8.1.4	18	27
	9.12.1.5	6	
	9.8.5.1	3	
4	8.4.1.1	13	37
	9.2.1.4	13	
	9.9.5.2	11	
5 E	7.3.2.1	14	31
	9.4.2.2	7	
	9.1.2.4	10	
6	7.5.5.3	15	32
	9.4.3.2	5	
	9.1.2.6	12	
7 D	8.8.6.1	21	32
	9.8.1.1	7	
	9.1.5.2	4	
8	1.3.16.3	21	35
	9.1.5.1	2	
	9.1.2.1	4	
	9.1.2.3	8	
9 B	7.2.2.1	6	29
	9.2.3.6	12	
	9.9.3.4	11	
10	2.1.2.1	14	14
<b>Total K = 320</b>		<b>(max K = 320)</b>	

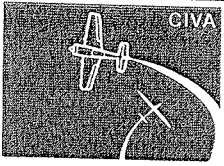

Pilote ID

CIVA Advanced Programme1

Form B

Vol N°

15

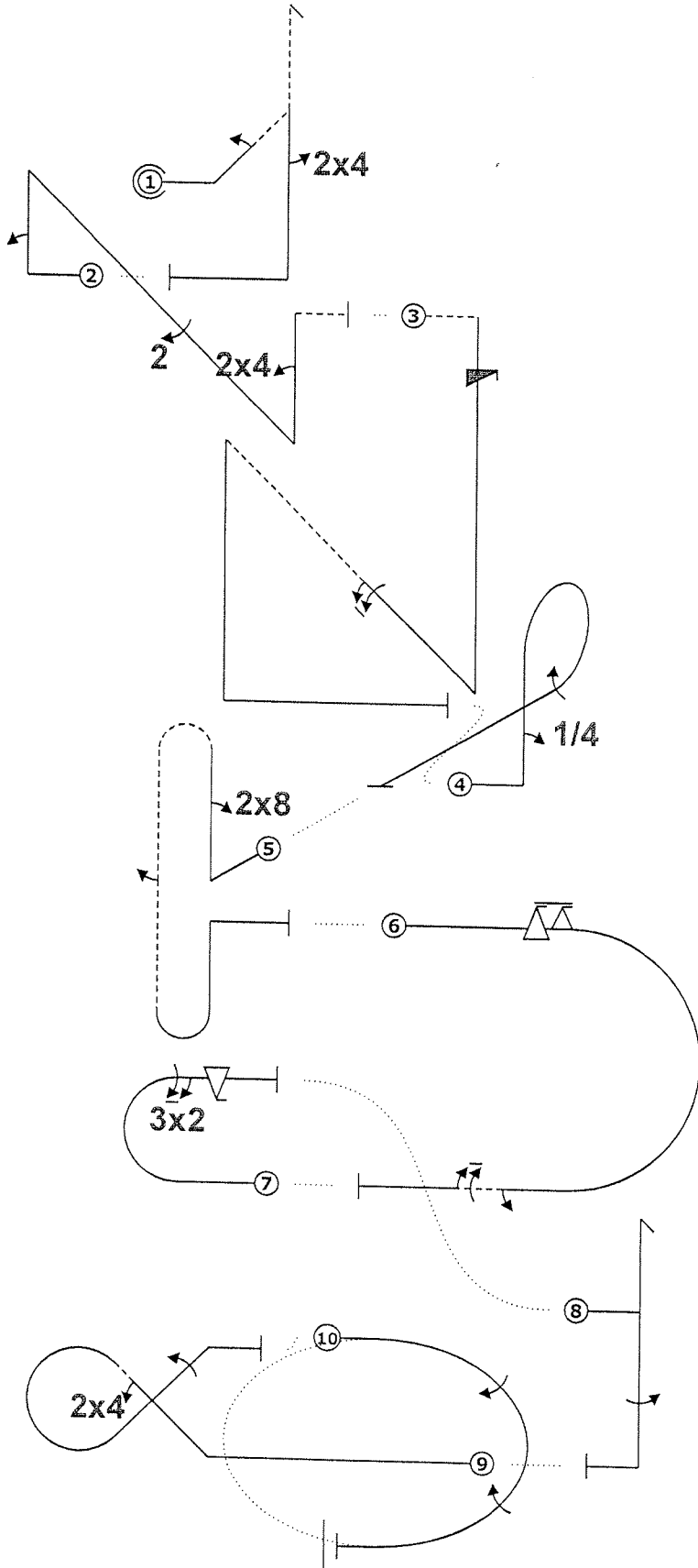

Avion			
Fig	Aresti	K	
1 A	5.3.2.1	24	35
	9.1.2.2	6	
	9.4.5.2	5	
2 C	1.3.14.1	22	48
	9.1.1.2	8	
	9.2.4.4	9	
	9.4.1.2	9	
3	1.3.11.4	20	39
	9.12.1.4	7	
	9.1.2.6	12	
4	8.6.1.1	11	25
	9.1.1.1	6	
	9.1.3.4	8	
5 D	8.8.6.1	21	32
	9.8.1.1	7	
	9.1.5.2	4	
6	7.2.3.3	6	34
	9.9.3.6	14	
	9.1.3.2	4	
	9.1.3.6	10	
7 B	7.2.2.1	6	29
	9.2.3.6	12	
	9.9.3.4	11	
8	5.2.1.1	17	25
	9.1.5.4	8	
9 E	7.3.2.1	14	31
	9.4.2.2	7	
	9.1.2.4	10	
10	2.2.5.1	22	22
<b>Total K = 320</b> (max K = 320)			

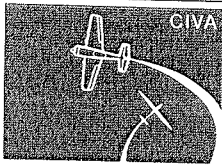

FAI

AEROBATICS  
COMMISSION

Pilote ID

CIVA Advanced Free Known

Form B

Vol N°

16

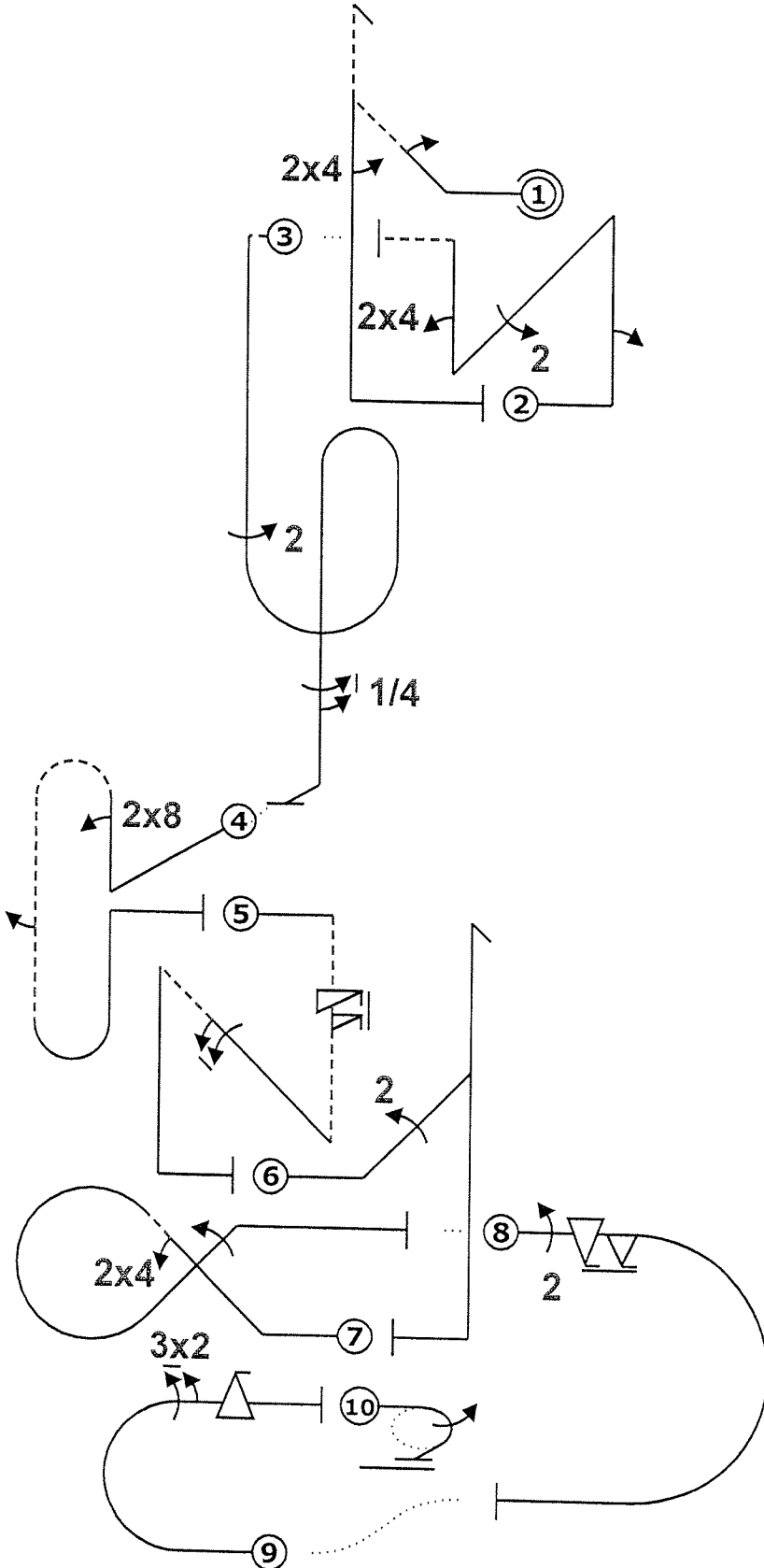

**Avion**

Fig	Aresti	K	
1 A	5.3.2.1	24	35
	9.1.2.2	6	
	9.4.5.2	5	
2 C	1.3.14.1	22	48
	9.1.1.2	8	
	9.2.4.4	9	
	9.4.1.2	9	
3	8.8.1.4	18	36
	9.2.5.4	9	
	9.1.5.5	9	
4 D	8.8.6.1	21	32
	9.8.1.1	7	
	9.1.5.2	4	
5	1.3.16.3	21	36
	9.11.1.6	3	
	9.1.2.6	12	
6	5.3.1.1	18	29
	9.2.2.4	11	
7 E	7.3.2.1	14	31
	9.4.2.2	7	
	9.1.2.4	10	
8	7.2.3.3	6	29
	9.2.3.4	9	
	9.9.3.6	14	
9 B	7.2.2.1	6	29
	9.2.3.6	12	
	9.9.3.4	11	
10	2.1.3.3	15	15

**Total K = 320**  
(max K = 320)



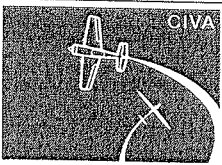

FAI

AEROBATICS  
COMMISSION

Pilote ID		CIVA Advanced Programme1	Form B
			Vol N° 17

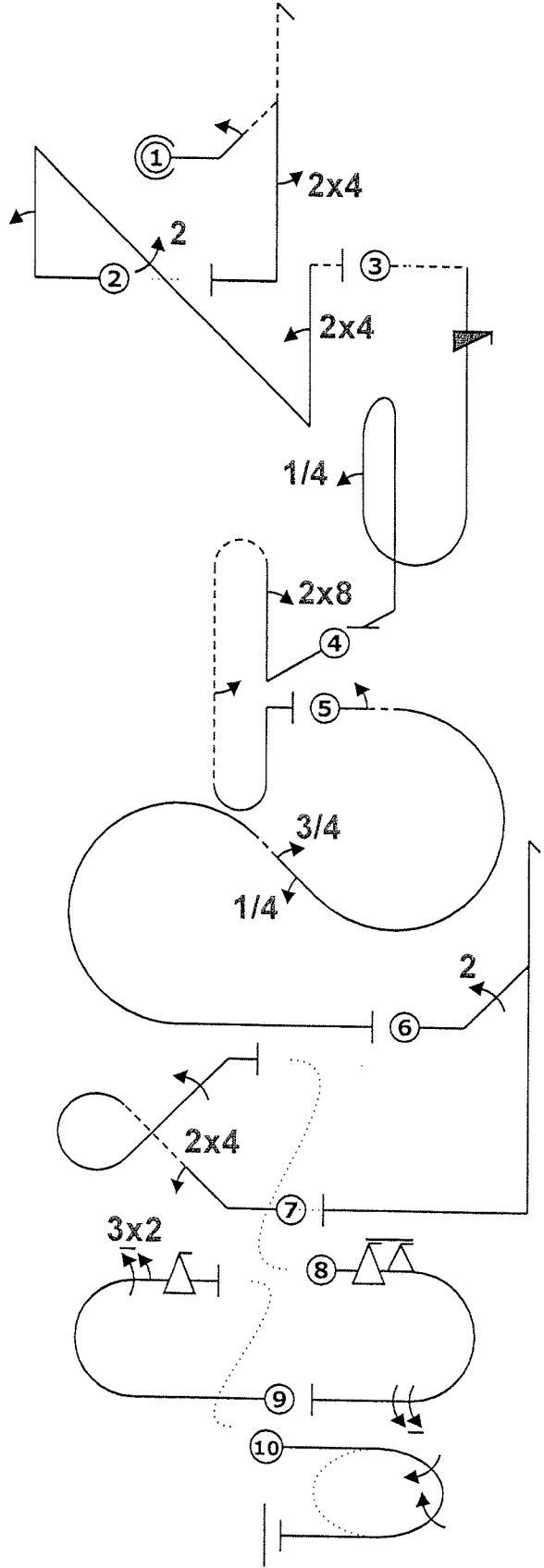

Avion			
Fig	Aresti	K	
1 A	5.3.2.1	24	35
	9.1.2.2	6	
	9.4.5.2	5	
2 C	1.3.14.1	22	48
	9.1.1.2	8	
	9.2.4.4	9	
	9.4.1.2	9	
3	8.8.1.4	18	31
	9.12.1.4	7	
	9.1.1.1	6	
4 D	8.8.6.1	21	32
	9.8.1.1	7	
	9.1.5.2	4	
5	7.5.5.3	15	31
	9.1.3.2	4	
	9.1.2.1	4	
	9.1.2.3	8	
6	5.3.1.1	18	29
	9.2.2.4	11	
7 E	7.3.2.1	14	31
	9.4.2.2	7	
	9.1.2.4	10	
8	7.2.3.3	6	32
	9.9.3.6	14	
	9.1.3.8	12	
9 B	7.2.2.1	6	29
	9.2.3.6	12	
	9.9.3.4	11	
10	2.2.5.1	22	22
<b>Total K = 320</b> (max K = 320)			

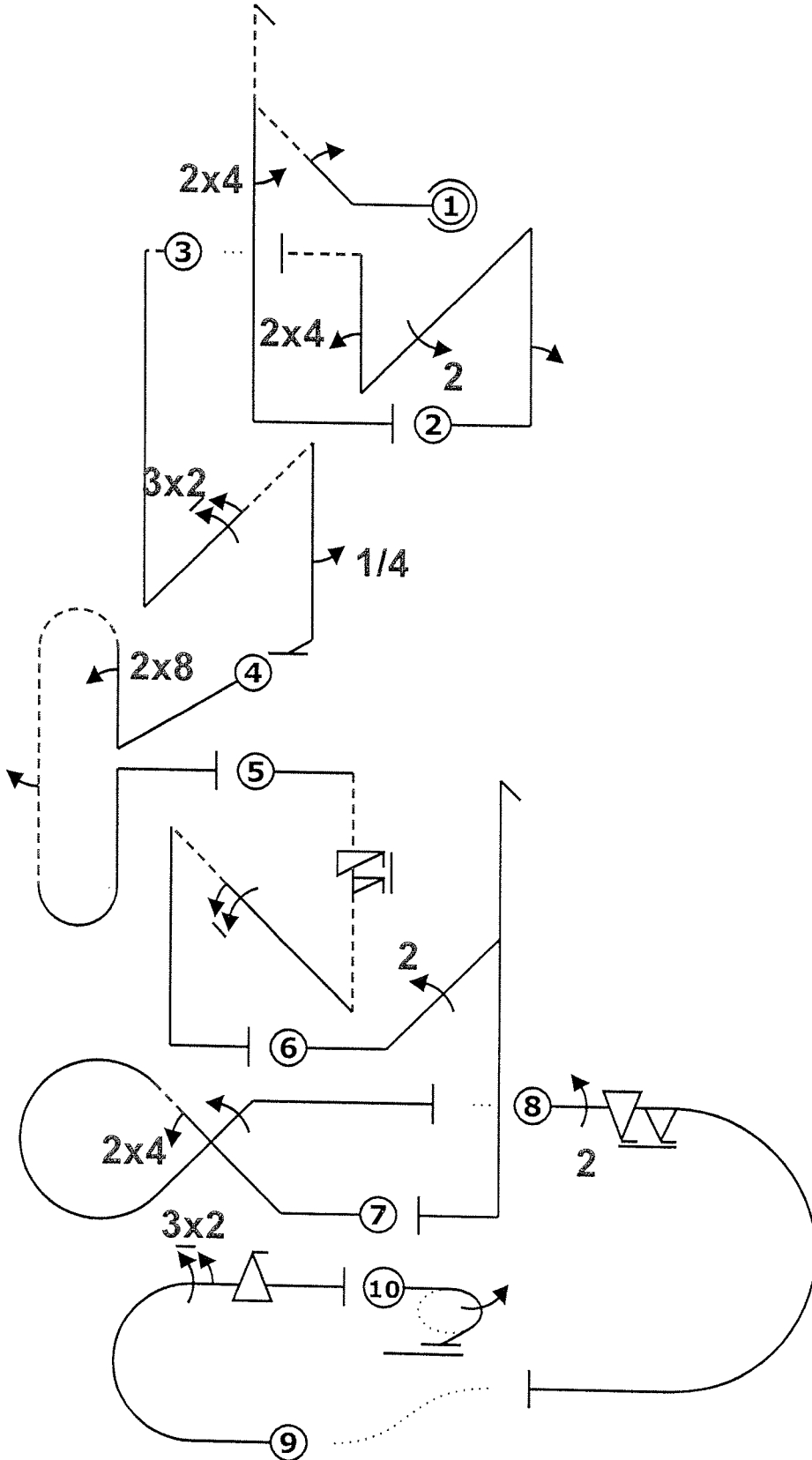
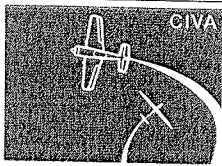

Avion			
Fig	Aresti	K	
1 A	5.3.2.1	24	35
	9.1.2.2	6	
	9.4.5.2	5	
2 C	1.3.14.1	22	48
	9.1.1.2	8	
	9.2.4.4	9	
	9.4.1.2	9	
3	1.3.11.4	20	36
	9.2.2.6	14	
	9.1.5.1	2	
4 D	8.8.6.1	21	32
	9.8.1.1	7	
	9.1.5.2	4	
5	1.3.16.3	21	36
	9.11.1.6	3	
	9.1.2.6	12	
6	5.3.1.1	18	29
	9.2.2.4	11	
7 E	7.3.2.1	14	31
	9.4.2.2	7	
	9.1.2.4	10	
8	7.2.3.3	6	29
	9.2.3.4	9	
	9.9.3.6	14	
9 B	7.2.2.1	6	29
	9.2.3.6	12	
	9.9.3.4	11	
10	2.1.3.3	15	15
<b>Total K = 320</b> (max K = 320)			

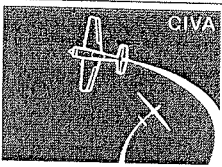

FAI

AEROBATICS  
COMMISSION

		Form B
Pilote ID	CIVA Advanced Programme1	Vol N° 19

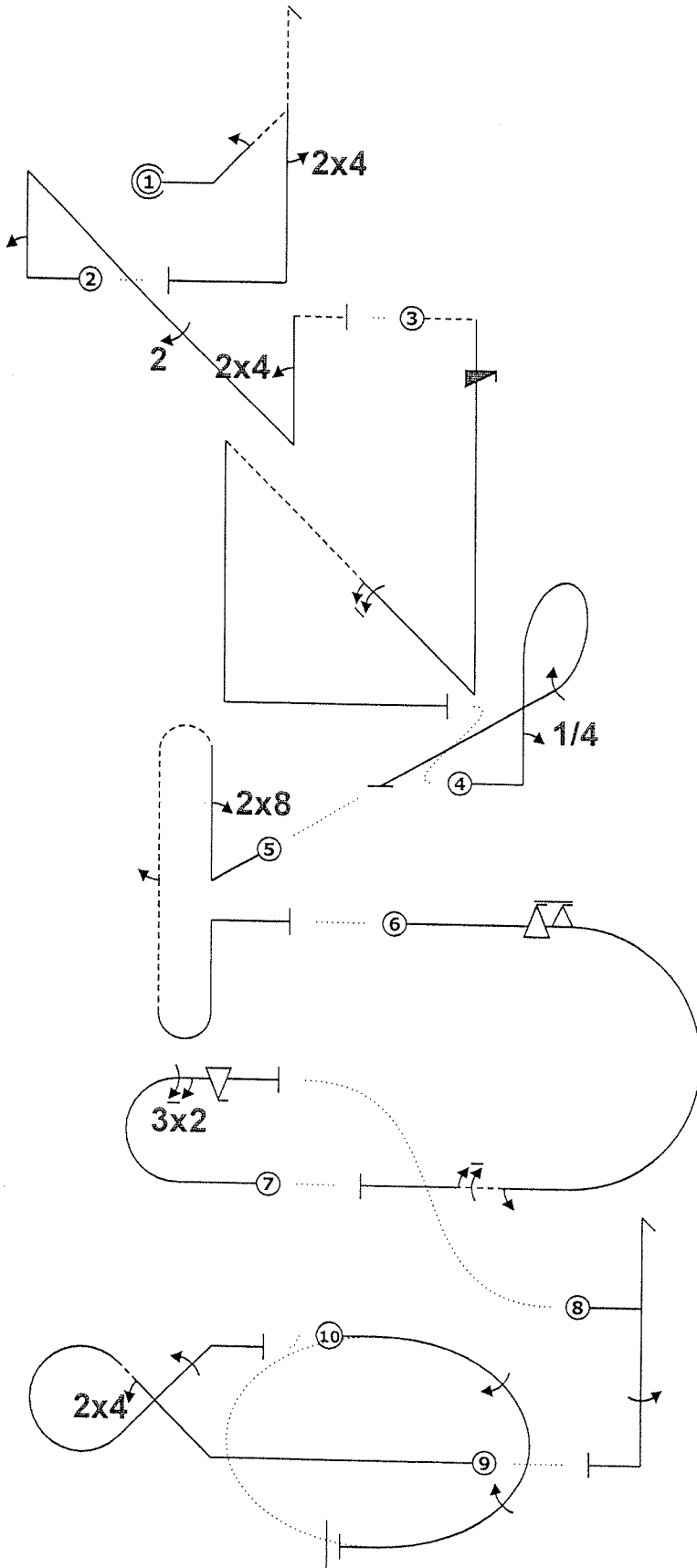

Avion			
Fig	Aresti	K	
1 A	5.3.2.1	24	35
	9.1.2.2	6	
	9.4.5.2	5	
2 C	1.3.14.1	22	48
	9.1.1.2	8	
	9.2.4.4	9	
	9.4.1.2	9	
3	1.3.11.4	20	39
	9.12.1.4	7	
	9.1.2.6	12	
4	8.6.1.1	11	25
	9.1.1.1	6	
	9.1.3.4	8	
5 D	8.8.6.1	21	32
	9.8.1.1	7	
	9.1.5.2	4	
6	7.2.3.3	6	34
	9.9.3.6	14	
	9.1.3.2	4	
	9.1.3.6	10	
7 B	7.2.2.1	6	29
	9.2.3.6	12	
	9.9.3.4	11	
8	5.2.1.1	17	25
	9.1.5.4	8	
9 E	7.3.2.1	14	31
	9.4.2.2	7	
	9.1.2.4	10	
10	2.2.5.1	22	22
<b>Total K = 320</b>		<b>(max K = 320)</b>	

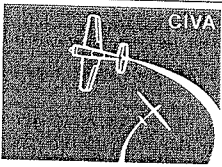

CIVA

FAI

AEROBATICS  
COMMISSION

Form B

Pilote ID

CIVA Advanced Programme 1

Vol N°

20

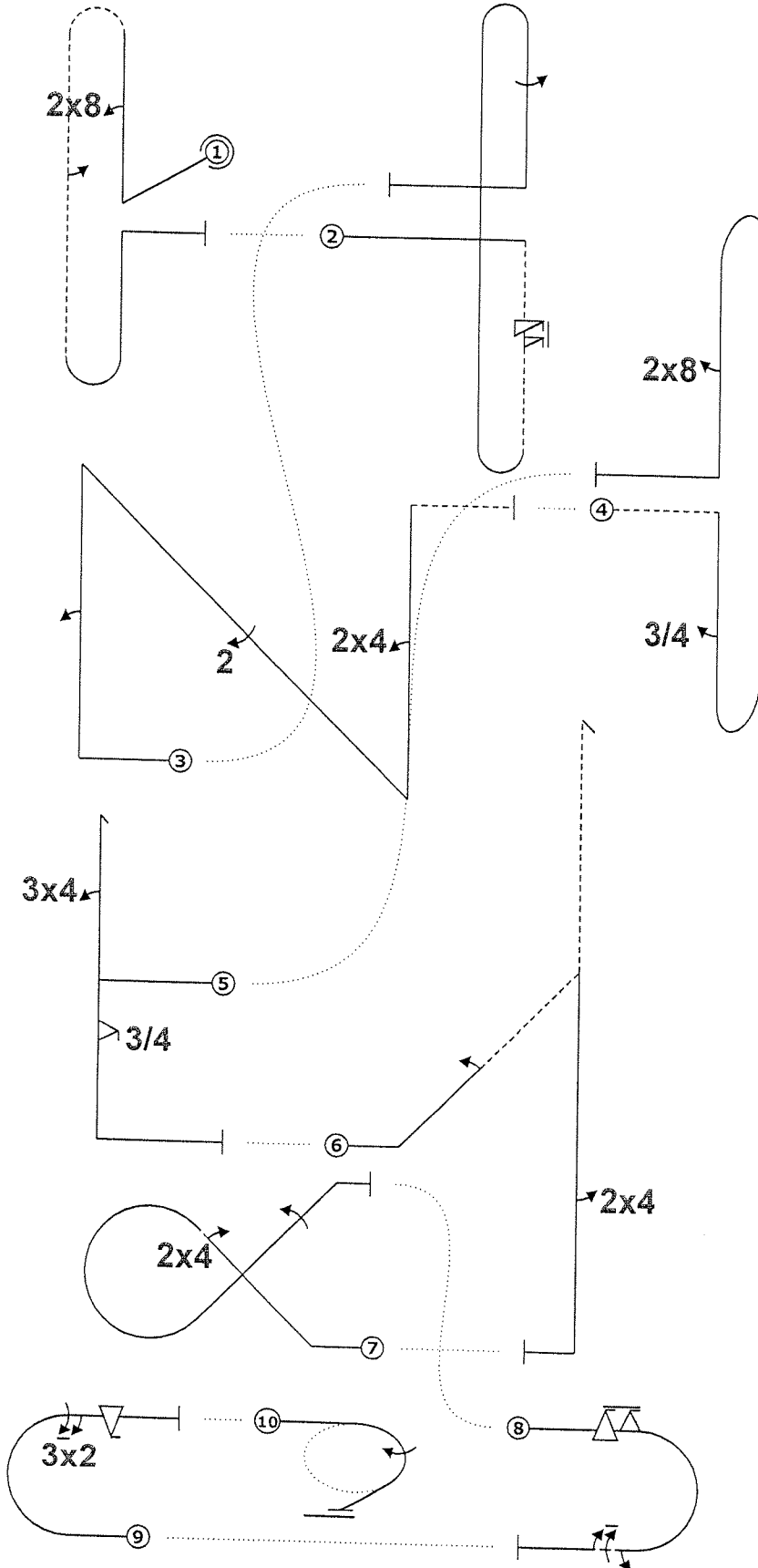
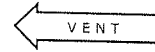

Avion		
Fig	Aresti	K
1 D	8.8.6.1	21
	9.8.1.1	7
	9.1.5.2	4
2	8.8.8.3	19
	9.11.1.6	3
	9.1.5.4	8
3 C	1.3.14.1	22
	9.1.1.2	8
	9.2.4.4	9
	9.4.1.2	9
4	8.8.1.4	18
	9.1.5.3	6
	9.8.5.1	3
5	5.2.1.1	17
	9.4.1.3	12
	9.9.5.3	11
6 A	5.3.2.1	24
	9.1.2.2	6
	9.4.5.2	5
7 E	7.3.2.1	14
	9.4.2.2	7
	9.1.2.4	10
8	7.2.3.3	6
	9.9.3.6	14
	9.1.3.2	4
	9.1.3.6	10
9 B	7.2.2.1	6
	9.2.3.6	12
	9.9.3.4	11
10	2.1.3.1	14
<b>Total K = 320</b>		
(max K = 320)		

Pilote ID		Form B
France Advanced connu-libre		Vol N° 21

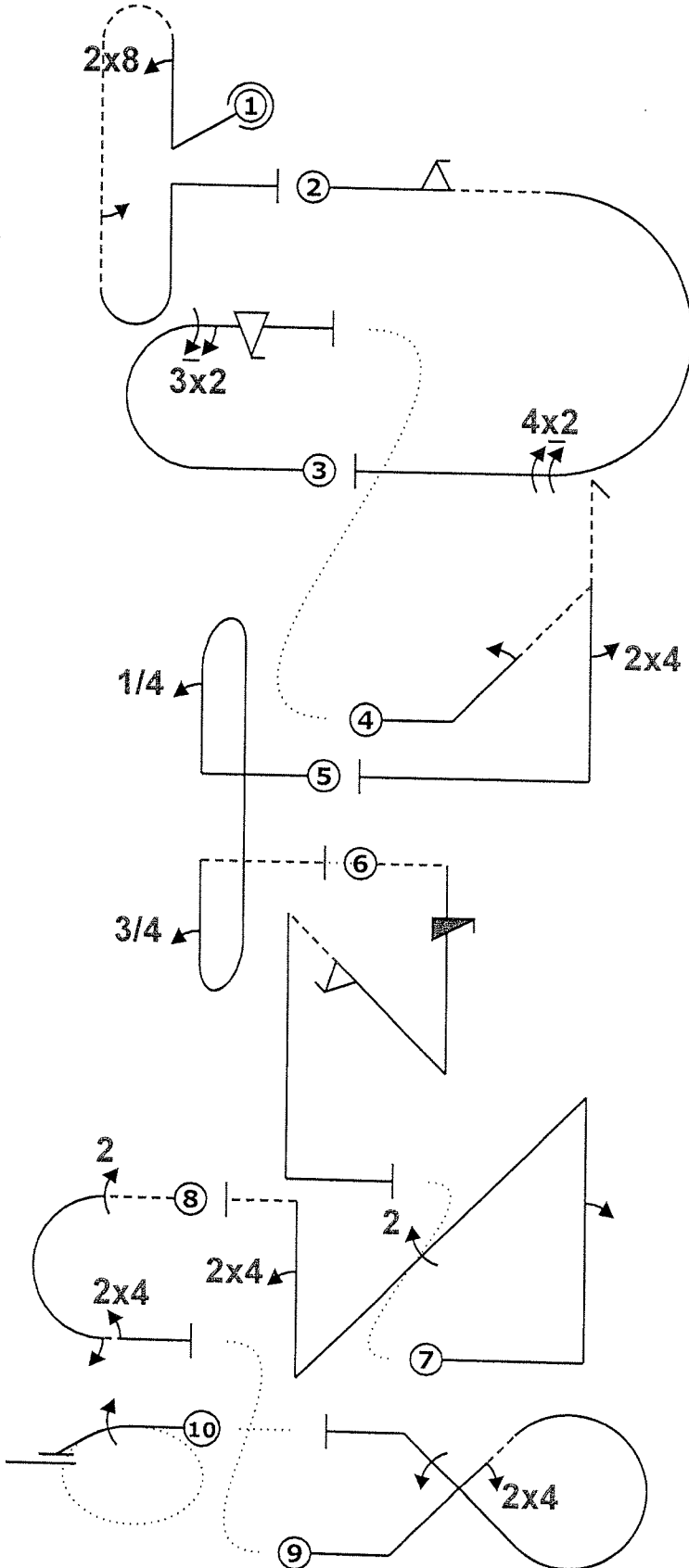

Avion			
Fig	Aresti	K	
1 D	8.8.6.1	21	32
	9.8.1.1	7	
	9.1.5.2	4	
2	7.2.3.3	6	32
	9.9.3.2	11	
	9.2.3.8	15	
3 B	7.2.2.1	6	29
	9.2.3.6	12	
	9.9.3.4	11	
4 A	5.3.2.1	24	35
	9.1.2.2	6	
	9.4.5.2	5	
5	8.8.1.1	18	34
	9.1.1.1	6	
	9.1.1.3	10	
6	1.3.11.4	20	40
	9.12.1.4	7	
	9.9.2.2	13	
7 C	1.3.14.1	22	48
	9.1.1.2	8	
	9.2.4.4	9	
	9.4.1.2	9	
8	7.2.1.4	6	24
	9.2.3.4	9	
	9.1.3.2	4	
	9.4.3.2	5	
9 E	7.3.2.1	14	31
	9.4.2.2	7	
	9.1.2.4	10	
10	2.1.3.3	15	15
<b>Total K = 320</b> (max K = 320)			